

# 落差フリューム

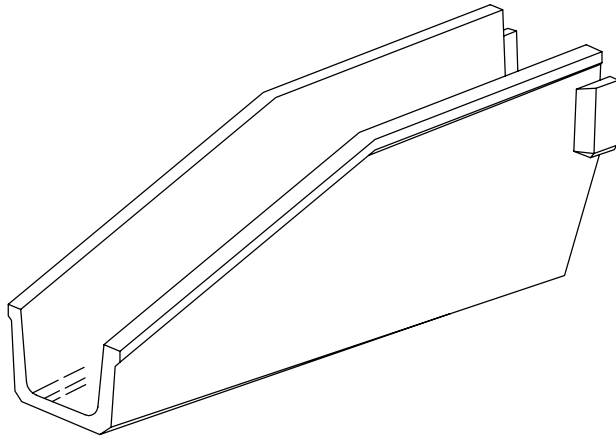

呼び名	重量(kg)
RF 250	210
RF 300	263
RF 350	321
RF 400	372
RF 500	505
RF 600	618

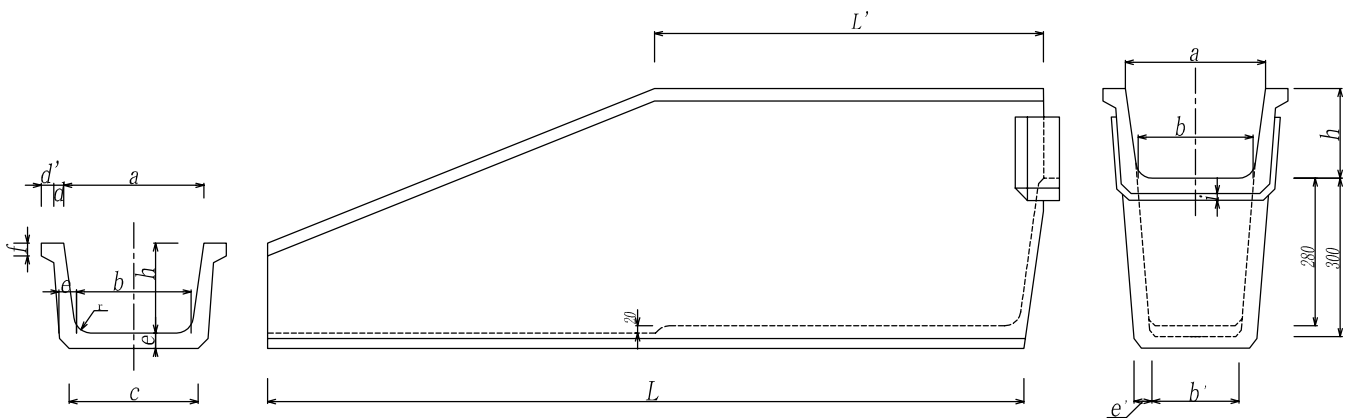

呼び名	寸 法 (mm)													鉄 筋			
	a	b	b'	c	d	d'	e	e'	f	h	i	r	L	横鉄筋		横鉄筋	
														径(mm)	本	径(mm)	本
RF 250	250	215	155	250	30	20	35	55	30	175	30	30	2000	3.2	10	3.2	20
RF 300	300	260	200	300	30	20	40	60	30	200	30	40		4.0		11	
RF 350	350	300	236	345	35	25	45	65	35	235	35	50			13		
RF 400	400	345	282	395	40	30	50	70	40	260	35	50		5.0	14	5.0	
RF 500	500	435	374	490	45	35	55	75	45	320	40	60			15		
RF 600	600	520	474	580	45	35	60	80	50	380	45	60					